



FUEL MANAGEMENT SYSTEMS



DISPENSERS



KITS



PUMPS



METERS



NOZZLES

FLANGED CONNECTIONS

FEATURES

- STURDY DESIGN
- EASY TO FIT
- SEVERAL SHAPES

Safe and guaranteed solutions to connect products: connections, elbows, full kits and flanges.

TECHNICAL DATA

CODE	DESCRIPTION	INLET / OUTLET				FLANGE	O-RING	OVAL RING	SCREW		GRUB SCREW	NUT
		A	B	C	H				M8X20 N°	M8X30 N°		

FLANGES

FO883200A	FLANGE D.80 1" E80/E120	-	1" BSP	80 MM	18 MM	-	-	-	-	-	-	-
F1290400A	KIT FLANGE 1" BSP	-	1" BSP	80 MM	18 MM	1	-	1	-	2	-	2
FO918000A	KIT FLANGE 1" BSP (2 PCS)	-	1" BSP	80 MM	18 MM	2	2	-	4	-	-	-
F1106200B	KIT FLANGE CUBE 70	-	1" BSP	80 MM	18 MM	1	1	-	2	-	-	-
RO841700O	KIT N°2 OR SEAL 3156	-	-	-	-	-	2	-	-	-	-	-
F1444500A	KIT FLANGE 3/4" BSP (2 PCS)	-	3/4" BSP	80 MM	18 MM	2	2	-	4	-	-	-
FO898500A	OR SEAL 3156 , OVAL SECTION	-	-	-	-	-	-	1	-	-	-	-
RO977900A	KIT FLANGE FOR PANTHER WITH K33	-	-	-	-	1	2	-	-	-	2	2
FO804300O	SCREW M8X30 N°10 PIECES	-	-	-	-	-	-	-	-	10	-	-
F1290600A	FLANGED KIT WITH NUT	-	-	-	-	1	-	-	-	-	-	2



FLANGE

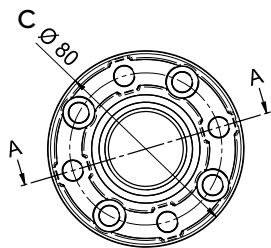

SCREW



NUT



FLANGE



O-RING



OVAL RING



GRUB SCREW

FLANGE KIT

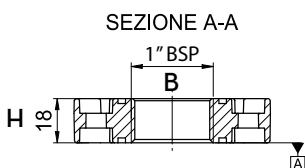



FILTRATION



TANK MONITORING



HOSE REEL



ACCESSORIES



MERCHANDISE

PIUSI



ANY BIODIESEL



AIR



ANTIFREEZE



AdBlue®



BIODIESEL



DIESEL



FOOD



GASOLINE



GREASE



KEROSENE



OIL



WATER



WINDSCREEN

TECHNICAL DATA

CODE	DESCRIPTION	DIMENSIONS	FLANGE	O-RING	OVAL RING	SCREW				GRUB SCREW	NUT
		LENGTH	N°	N°	N°	M8X16 N°	M8X20 N°	M6X16 N°	M8X30 N°	M8X50 N°	M8 N°

FLANGED TUBE

F1217200A	FLANGED TUBE 341MM\$	341	-	-	-	-	-	-	-	-	-
F1222800B	FLANGED TUBE 300MM	300	-	-	-	-	-	-	-	-	-
R13251000	KIT TUBO RACC-FLANG. SELF.S. TANK FM+MC	205	-	2	-	2	2	-	-	-	-

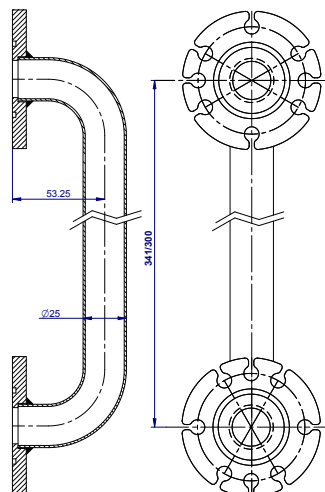

FLANGED TUBE 300/341



TECHNICAL DATA

CODE	DESCRIPTION	DIMENSIONS	FLANGE	O-RING	OVAL RING	SCREW				GRUB SCREW	NUT
		LENGTH	N°	N°	N°	M8X16 N°	M8X20 N°	M6X16 N°	M8X30 N°	M8X50 N°	M8 N°

FLANGED ELBOW

F1082400A	KIT FLANGED ELBOW + OR + SCREW	-	-	2	-	-	2	-	2	-	2
-----------	--------------------------------	---	---	---	---	---	---	---	---	---	---

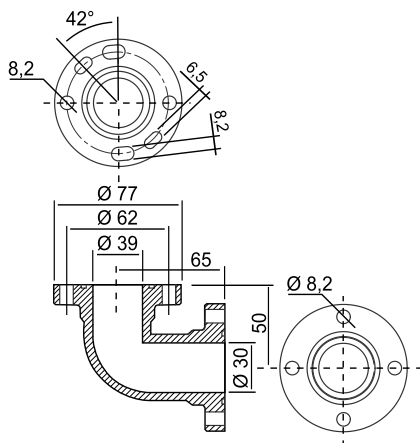

ELBOW



SCREW



NUT



FLANGE



O-RING