



CAR FILLING



FUEL MANAGEMENT SYSTEMS



KITS



PUMPS



METERS



METERED NOZZLES

B.SMART

FEATURES

- SIMPLE, INTUITIVE, SUITABLE FOR EVERYONE
- UNLIMITED TO FIT ALL NEED
- MONO OR MULTI-SITE
- SOFTWARE ALWAYS INCLUDED WITH THE DISPENSER
- BLUETOOTH
- CLOUD-BASED
- NO SOFTWARE INSTALLATION
- NO FEE
- ANALYSIS, CONTROL AND MANAGEMENT IN ONE CLICK

PERFORMANCE

<p>DATA</p> <p>AVAILABLE</p> <p>ALWAYS</p> <p>TRANSACTIONS</p>	<p>NO</p> <p>SOFTWARE</p> <p>ON THE PC</p> <p>CLOUD</p>
<p>NO FEE</p> <p>UTILIZATION</p>	<p>ONLY</p> <p>BLUETOOTH</p> <p>NO WI-FI OR LAN</p> <p>CONNECTION</p>

B.SMART is the Fuel Management System (FMS) by PIUSI designed and engineered for fleets of all sizes: small, medium, large, mono or multi-site. Innovative, simple and smart - the name carries its meaning - PIUSI B.SMART combines the quality and efficiency of PIUSI dispensers, with a Cloud-based software (APP for drivers and a web APP for fleet managers) driven by Bluetooth technology; that means no Wi-Fi or LAN network are required. Thus, it is possible to use B.SMART wherever; also in the more distant areas. A FMS all in one: the fleet manager has just to choose the necessary dispensers; the software is always included in the "package" (no rental ore recurring fee will be required).



B.SMART

B.SMART is flexible and expandable: the same system easily fits to all requirements. It is only necessary to add the add-on needed to keep up with the evolution of the fleet.

B.SMART API AVAILABLE

CONNECT YOUR ERP TO B.SMART WITH THE INTEGRATED API INTERFACE.





NOZZLES



FILTRATION



TANK MONITORING



HOSE REEL



ACCESSORIES



MERCHANDISE



AIR



ANTIFREEZE



AdBlue®



BIODIESEL



DIESEL



FOOD



GASOLINE



GREASE



KEROSENE



OIL



WATER



WINDSCREEN



APP

Dedicated to drivers, the APP for drivers just needs a smart device with Bluetooth to work properly: once the APP is open, the smartphone or tablet immediately connects to the dispenser to start the refueling operation.



HARDWARE

PIUSI B.SMART runs only with the dedicated range of dispensing devices: quality guaranteed by PIUSI; the highest technical performances and reliability, all form a unique supplier. Real time communication between the dispenser and the PC.



CLOUD

The core of B.SMART fuel management software is a Cloud-based service that tracks every refuelling operation and keeps every device synchronized.



WEB APP

Dedicated to fleet manager. No software installation: just log in and start immediately to monitor, manage and control consumptions of the fleet.



CAR FILLING



FUEL MANAGEMENT SYSTEMS



KITS



PUMPS



METERS



METERED NOZZLES

ADD-ONS



ADD-ON

Once the ADD-ON is chosen, PIUSI will send an activation code with all related instructions.

DRIVER ADD-ON

CODE	DESCRIPTION
F22500000	DRIVER ACCESS ADD-ON B.SMART (X10)
FO0770D20	DRIVER ACCESS ADD-ON B.SMART (X50)

TANK WATCHDOG

B.SMART Tank Watchdog is the perfect add on for a complete and updated control of the stock. It allows you to:

- monitor the tank level (add fluid loads and unloads and adjustments);
- set level alarms;
- manage suppliers;
- follow inventory price values and trends;
- access and download reports from anywhere

TANK WATCHDOG ADD-ON

CODE	DESCRIPTION
FO0770L00	B.SMART TANK WATCHDOG ADD-ON - 1 YEAR
FO0770L20	B.SMART TANK WATCHDOG ADD-ON - ONE TIME FEE

Tank levels

Adding the level indicator OCIO, the system allows you to monitor the fluid level in your tanks in real time and gives alarms in case of malfunction or low levels. A perfect add-on for a complete and updated control of the stock. You can connect also any 420 mA o O-10 V fluid gauge or run the system without any gauge thanks to the “virtual tank” option:

- set level alarms and get notifications on the tank level;
- possibility to configure high level or low level alarms;
- stop the pump according to the level of the fluid;
- send an automatic e-mail to notify when you reach the level alarm set.

Fluid price and values

Thank to the level indicator OCIO you can have at your fingertips the fluid inventory value & quantity: you can define the refuelling price and verify the current inventory value.

- manage suppliers of the fluids to keep track of the date, price and quantity bought;
- get real time data of the value of your inventory;
- follow fluids price trends;
- access and download reports from any internet connected device thanks to the software cloud.

FUEL ECONOMY

Enhance your system and become even more smart with the Fuel Economy ADD-ON for B.SMART! Thanks to this new module, you can now completely manage and increase the profitability of your fleet:

- manage consumptions, cross-checking vehicles and drivers;
- manage drivers' and vehicles' limits;
- add, check and manage the on-road refuellings.





NOZZLES



FILTRATION



TANK MONITORING



HOSE REEL



ACCESSORIES



MERCHANDISE



AIR



ANTIFREEZE



AdBlue®



BIODIESEL



DIESEL



FOOD



GASOLINE



GREASE



KEROSENE



OIL



WATER



WINDSCREEN

Fleet management & limits

Thanks to this new add-on, you can:

- add to the B.SMART WEB APP system all the vehicles of your fleet;
- group all the vehicles according to a specific and personalized setting;
- add to the WEB APP the images of your vehicles and drivers for a quickest and easy identification;
- set drivers and vehicles limits based on quantities or time frames

FUEL ECONOMY ADD-ON

CODE	DESCRIPTION
FO0770FOO	B.SMART FUEL ECONOMY ADD-ON 1 YEAR
FO0770F20	B.SMART FUEL ECONOMY ADD-ON ONE TIME FEE
F17299Q00	B.SMART FUEL ECONOMY 45 QR CODES

Consumptions report

Thanks to this new add-on, you can have detailed reports of:

- fuel/AdBlue® dispenses;
- vehicles' consumptions, spotting deviations vs standard;
- drivers' consumption on vehicles, tracking the driving behaviour of the operator;
- spot drivers' high fuel consumption;
- add on-road transactions highlighting also fuel/AdBlue® costs and the service station used in order to have a complete overview on the trend/activities of both drivers and vehicles.

MAPLY

The add-on is specifically designed for companies working in construction, mining, excavation, drilling, landscaping or agriculture that want to have all the information at-a-glance including GPS location of fuel dispensing. With Maply Add-on it is possible:

- reduce fuel waste
- increase company profitability
- monitor & control fuel dispensing

Geolocation

- Geolocate fuel transactions and display them on a map;
- "report on map" gives an overview of fuel dispensing. Clicking on a fuel transaction you get all the relevant data (quantity, date, time, vehicle refuelled, etc.)

Manage fluid handover from fixed to mobile tanks

- Automatically manage portable tank loads;
- fuel transfer information will be managed inside the B.Smart reporting system, increasing information effectiveness.

3rd parties vehicles refuelling

- Track fuel transactions on third-party vehicles;
- possibility to send e-mail notifications and add operator's notes.

MAPLY ADD-ON

CODE	DESCRIPTION
FO0770M00	B.SMART MAPLY ADD-ON - 1 YEAR
FO0770M20	B.SMART MAPLY ADD-ON - ONE TIME FEE

AVAILABLE KITS ADD-ON

KIT ADD-ON

CODE	DESCRIPTION
FO0770K00	KIT TANK WATCHDOG + FUEL ECONOMY 1 YEAR
FO0770K20	KIT TANK WATCHDOG + FUEL ECONOMY ONE TIME FEE
FO0770K40	KIT TANK WATCHDOG + FEM + MAPLY 1 YEAR
FO0770K60	KIT TANK WATCHDOG + FEM + MAPLY ONE TIME FEE



CAR FILLING



FUEL MANAGEMENT SYSTEMS



KITS



PUMPS



METERS



METERED NOZZLES

SELF SERVICE B.SMART

FEATURES

- ACCESS CONTROL AND MANAGE ADBLUE® DELIVERY
- 3D FILTER INTEGRATED
- COMPACT DESIGN
- NATIVE WITH B.SMART CLOUD SOFTWARE
- KIT UPGRADE 1.0/2018 AVAILABLE

SELF SERVICE B.SMART for AdBlue® is the updated version of the famous PIUSI AdBlue® dispenser integrated with the fuel management system B.SMART! Starting from today, you can manage the consumption of AdBlue® of your fleet with this new and innovative urea dispenser.

PERFORMANCE

UP TO

32 L/MIN

FLOW RATE

VOLTAGE

AC

POWER

±1%

ACCURACY



SELF SERVICE B.SMART

PACKAGING

CODE	WEIGHT		PACKAGING			N. BOXES / EUROPALLET	
	KG	LBS	MM	INCH	PCS/BOX	✕	
FO0748020	48	105	1480X490X400	58.3X19.3X15.7	1		



NOZZLES



FILTRATION



TANK MONITORING



HOSE REEL



ACCESSORIES



MERCHANDISE



AIR



ANTIFREEZE



AdBlue®



BIODIESEL



DIESEL



FOOD



GASOLINE



GREASE



KEROSENE



OIL



WATER



WINDSCREEN

CHART

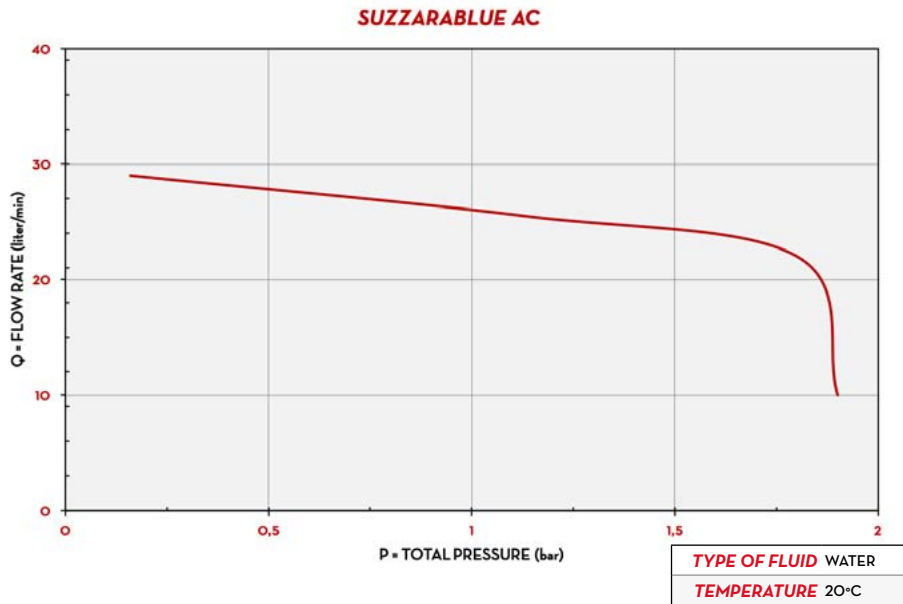

DIMENSIONS

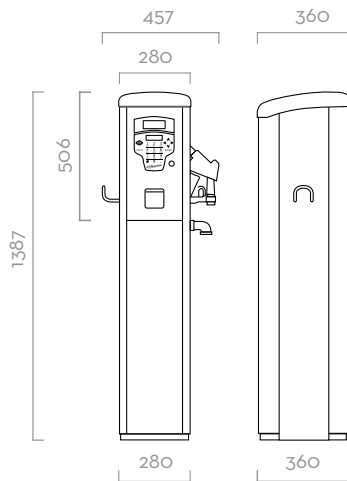

Dimensions expressed in millimeters

IN THE BOX

- SELF SERVICE B.SMART DISPENSER
- DELIVERY HOSE
- SB325_X NOZZLE
- DRIVER ACCESS ADD-ON
- INSTRUCTION MANUAL

DETAILS



3D FILTER



OCIO 2.0 ON REQUEST



B.SMART CLOUD SOFTWARE



B.SMART MOBILE APP

COMPONENTS

- **PUMP:**
SUZZARABLU PUMP AC
- **METER:**
K24
- **NOZZLE:**
SB325_X
- **FILTER:**
3D FILTER

TECHNICAL DATA

CODE	DESCRIPTION	FLUIDS TYPE	FLOW RATE		VOLTAGE			PUMP	METER	NOZZLE	FILTER	INLET	HOSE		
			L/MIN	GPM	AC V/HZ	DC VOLT	POWER WATT						AMP. MAX.	TYPE	LENGTH
FO0748020	SELF SERV ADBLUE 230V B.SMART 10 ACCESS		34	8,9	230 V	50 HZ	400 W	1.95 A	SUZZARABLU AC	K24	SB325_X	YES	3/4"	6 M	1"