



KITS



PUMPS



METERS



METERED NOZZLES



NOZZLES



WASTE OIL EQUIPMENTS

VISCOTROLL VANE

FEATURES

- HIGH CAPACITY PUMP
- READY TO USE
- ROTATING DISC FLOW METER (K33 ONLY)
- STURDY DESIGN CART

The PIUSI VISCOTROLL VANE is a mobile oil dispenser suitable to transfer low viscosity lubricants. This versatile mobile cart includes the AC powered PIUSI VISCOMAT PUMP, and SELF3000 manual nozzle.

PERFORMANCE

UP TO 25 L/MIN	BELOW 70 DB
FLOW RATE	NOISE LEVEL
± 1%	UP TO 500 cSt
ACCURACY	VISCOSITY



VISCOTROLL VANE

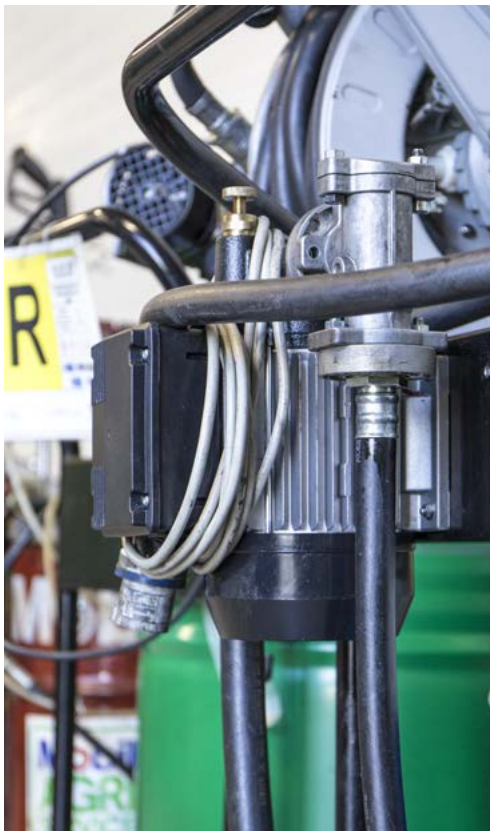

PACKAGING

CODE	WEIGHT		PACKAGING			
	KG	LBS	MM	INCH	PCS/PALLET	PCS/BOX
VISCOTROLL VANE						
000263100	34	75	1090X690X300	42,9X27,2X11,8		1
000263110	36	79,4	1090X690X300	42,9X27,2X11,8		1



FILTRATION



FLUID MONITORING



TANK MONITORING



HOSE REELS



ACCESSORIES



MERCHANDISE



AIR



ANTIFREEZE



AdBlue®



BIODIESEL



DIESEL



FOOD



GASOLINE



GREASE



KEROSENE



OIL



WATER



WINDSCREEN

CHART

VISCOMAT VANE

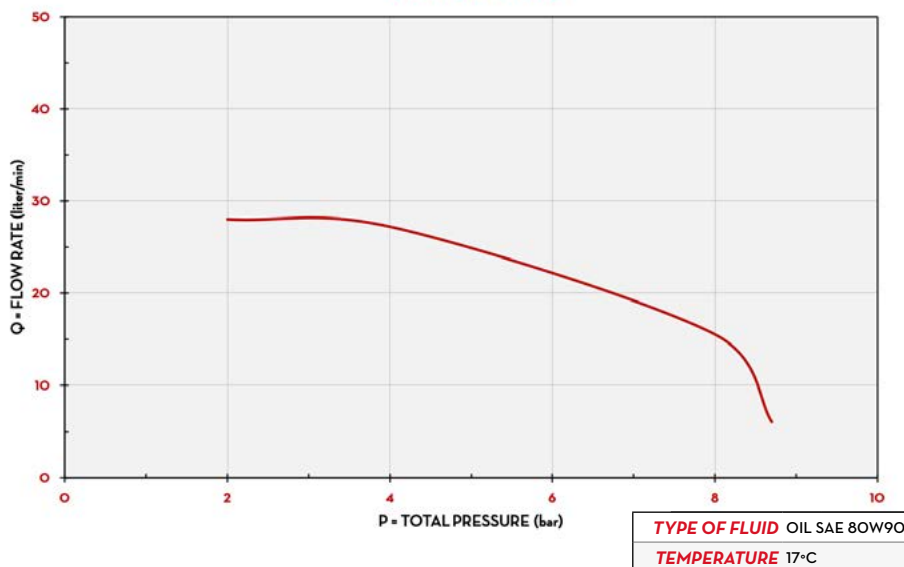

IN THE BOX

- VISCOMAT PUMP
- FOOT VALVE
- SELF3000 NOZZLE
- CART
- INSTRUCTION MANUAL

DETAILS



SELF3000 MANUAL NOZZLE



ON/OFF SWITCH



FOOT VALVE

DIMENSIONS

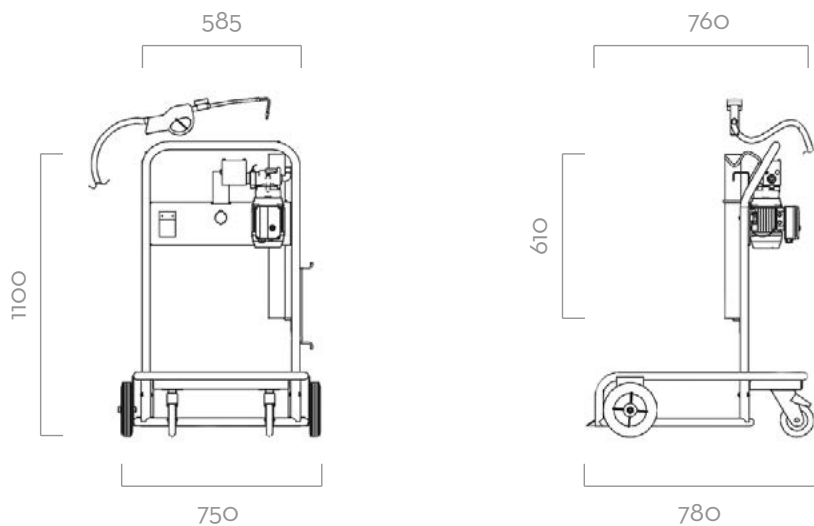

Dimensions expressed in millimeters

MATERIALS/COMPONENTS

- **PUMP:**
VISCOMAT VANE
- **METERS:**
K33
- **NOZZLE SELF3000:**
BODY: ALLUMINIUM
SEAL: VITON

TECHNICAL DATA

CODE	DESCRIPTION	FLUIDS TYPE	FLOW RATE		VISCOSITY CST MAX.	VOLTAGE			METER MOD.	PUMP MOD.	NOZZLE TYPE
			L/MIN	GPM		AC V _r /HZ DC VOLT	POWER WATT	AMP. MAX.			
000263100	VISCOTROLL 70		25	6,6	500	230/50	750	4,6	-	VISCOMAT 70M	SELF3000
000263110	VISCOTROLL 70/K33		25	6,6	500	230/50	750	4,6	K33	VISCOMAT 70M	SELF3000

UPON REQUEST IT IS AVAILABLE WITH DIFFERENT VOLTAGE AND FREQUENCY